



***MovieStar
Automated Lighting System***



PANALUX is one of the most accomplished, innovative lighting rental facilities in the world today.



PANALUX is an international market leader in the provision of lighting facilities spanning the full spectrum of film and television production; Feature Films, Television, Commercials, Music Video and Stills Shoots.

Our experienced, professional team, an extensive inventory of modern equipment and a solid understanding of our industry sets us apart from the competition.

Utilising these resources, clients continually entrust us to deliver practical lighting solutions throughout the world.

PANALUX have developed the revolutionary MovieStar, a lighting system designed to address the increasing demands from the film and television industry for safe, versatile, crane-mounted lighting

The heart of the system is the Movie Star automated fresnel head, available with a choice of light-sources - 12 or 18Kw HMI and 20Kw incandescent featuring remote controlled pan, tilt, spot/flood and dimmer attributes,

The unique Movie Star crane can accommodate one, two or three heads with a maximum mast height of 32m. Alternatively, the heads can be mounted directly onto existing structures such as trussing, scaffold tube, etc. or any suitable crane or cherry picker.

The Movie Star heads are effortlessly positioned and focused via remote control. Various control options include the very simple, custom PANALUX hand-held pendant remote.

Safety is high on the agenda and the system obviates the need for a person to be permanently stationed adjacent to the lamp head during a shoot, manually moving the lamps via clumsy walkie-talkie communications. This frees up an additional crew member to attend to other priorities at ground level.

Easy assembly is also a major feature. The Movie Star System has been specifically designed to be rigged by two people in a matter of minutes, allowing considerable cost and time savings.

The primary application for the Movie Star System will be in the film industry, providing key/back lighting for night exteriors and daylight enhancement from otherwise inaccessible positions. However, the system will also benefit outside broadcasts, concerts and event productions where its unique flexibility is ideal for a multiplicity of uses.



PANALUX is used to combining ingenuity with top quality products. The Movie Star has emanated from the company's wealth of expertise and experience in this area of professional lighting.

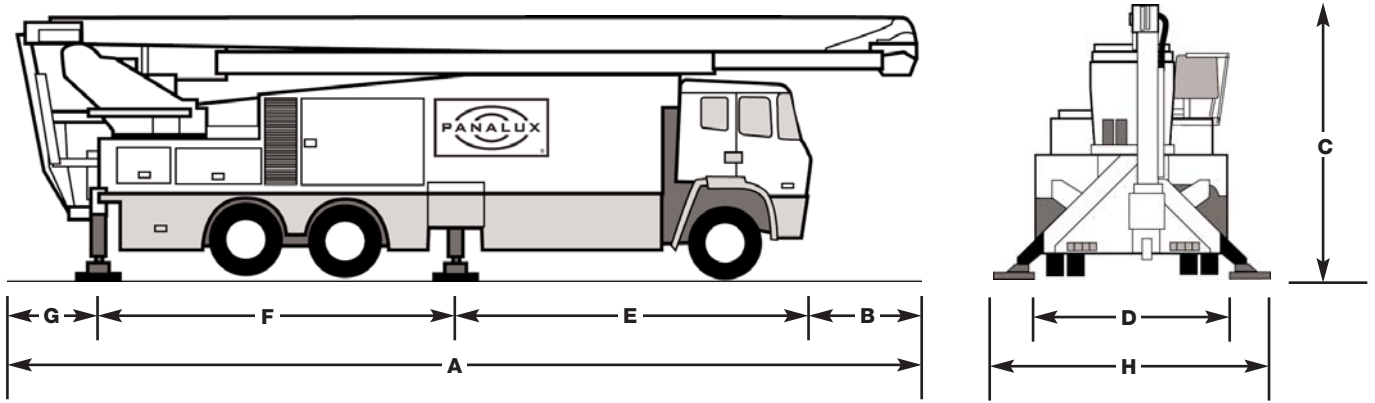

A	Overall Length	13.20	43' 4"	
B	Front Overhang	1.83	6'	
C	Travelling Height	3.80	12' 6"	
D	Travelling Width	2.54	8' 4"	
E	Front to Forward Jack Leg	5.57	18' 3"	
F	Jack Leg Centres	4.55	14' 11"	
G	Rear to Rear Jack Leg	1.25	4' 2"	
H1	Front Jack Spread Fully Extended	4.85	15' 11"	
H2	Rear Jack Spread Fully Extended	4.15	15' 8"	
	Travelling Weight			23700
	GVW Max			25800
Generator	140kW 3 Phase 0.2 BAC Outlets			

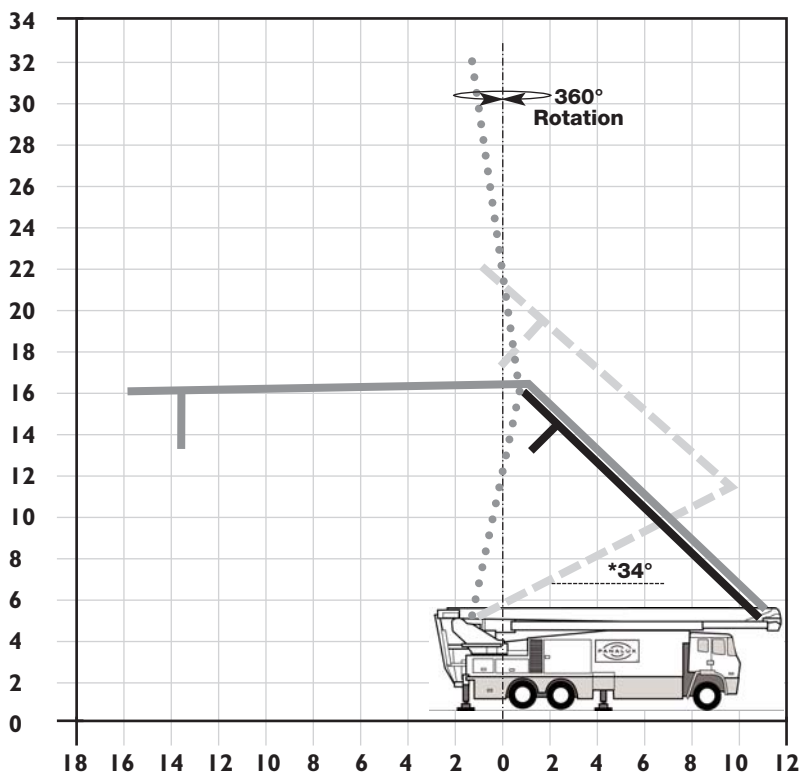

MovieStar Platform Reach Curve

* First boom angle must be greater than 34° to obtain 360° rotation

When first boom angle is less than 34° rotation must not exceed 30°

Photometric Information

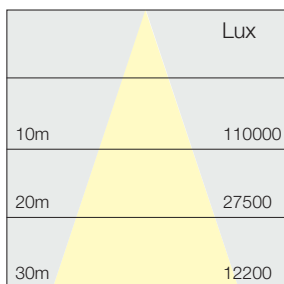

18kW HMI 5600°K
Spot

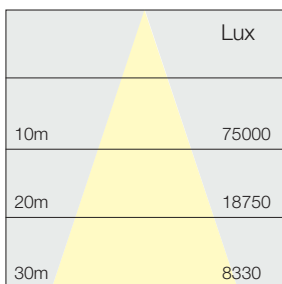

12kW HMI 5600°K
Spot

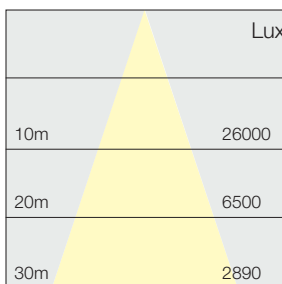

20kW tungsten 3200°K
Spot

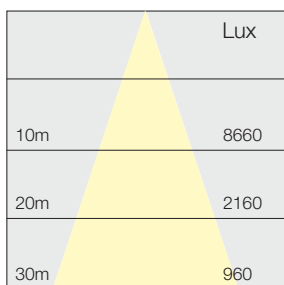

18kW HMI 5600°K
Flood

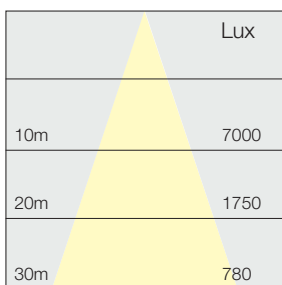

12kW HMI 5600°K
Flood

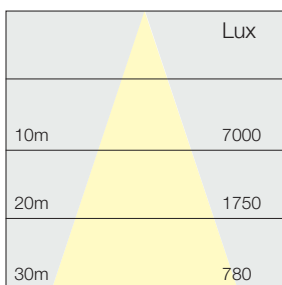

20kW tungsten 3200°K
Flood

Features

Extremely safe

**Fast and easy to set up
(two person rig in minutes)**

**Ideal for film shoots,
outside broadcasts,
concerts and event
productions**

**Choice of light source:
12 or 18kW HMI, 20kW
Quartz**

**Remote control of pan, tilt,
spot, flood and dimmer
control**

**Assorted control protocol
options**

1,2 or 3 heads



PANALUX

Waxlow Road, London NW10 7NU United Kingdom
Tel: (+44) 020 8233 7000

info@panalux.biz